

SUBMITTAL

Contractor's Stamp:	Notes:
<div style="border: 2px solid blue; padding: 5px;"> <p>SHOP DRAWING / SUBMITTAL REVIEW:</p> <p> <input checked="" type="checkbox"/> APPROVED <input type="checkbox"/> APPROVE WITH CHANGES NOTED <input type="checkbox"/> REVISE AND RESUBMIT <input type="checkbox"/> REJECTED </p> <p>Submittal was reviewed for design conformity and general conformance to Contract Documents only. The Subcontractor is responsible for confirming and correlating dimensions at jobsite for the tolerance, clearance, quantities, fabrication processes and techniques of construction. Coordination of His/Her work with other trades and full compliance with Contract Documents.</p> <p>By: <u>Tony Cannon</u> MACON BUILDING PROJECT MANAGER</p> <p style="text-align: center;">MACON BUILDING 662 HIGHLAND DRIVE - ALTAMONTE SPRING - FL - 32701</p> </div>	<p>"PLEASE USE REDTEAM FOR NOTES"</p>

Architect's Stamp:	Notes:
	<p>"PLEASE USE REDTEAM FOR NOTES"</p>

Engineer's Stamp	Notes:
<p style="text-align: center;">WTA, INC. CONSULTING ENGINEERS</p> <p> <input checked="" type="checkbox"/> APPROVED <input type="checkbox"/> APPROVED AS NOTED <input type="checkbox"/> NOT APPROVED <input type="checkbox"/> REVISE AND RE-SUBMIT </p> <p>REVIEWED AS AN AID TO THE CONTRACTOR ONLY. CONTRACTOR IS NOT RELIEVED OF RESPONSIBILITY FOR FULL COMPLIANCE WITH THE CONTRACT DOCUMENTS.</p> <p>DATE: <u>10.06.2020</u> BY: <u>Mark Martinez</u></p>	<p>"PLEASE USE REDTEAM FOR NOTES"</p>

PROJECT:

1260003

OWNER:

VERIZON

ARCHITECT:

JLL

BRIAN BOYLE CPE
C: 813-293-9163
BRIANBOYLE@AMJLL.COM

ENGINEER:

GRINER ENGINEERING, INC.
3125 FIFTH AVE. N.
SUITE 300
ST. PETERSBURG, FL.
33713
(727) 822-2335
JOSEPH H. GRINER

CONTRACTOR:

JIM MACON
BUILDING CONTRACTORS
INC.
TROY DAVIS

TITLE:

VERIZON GENERATOR
RADIATORS REPLACEMENT
TEMPLE TERRACE CENTER
7701 E. TELECOM PKWY.
TEMPLE TERRACE, FL.
33673

NOTES:

NUMBER: SCALE:

E1

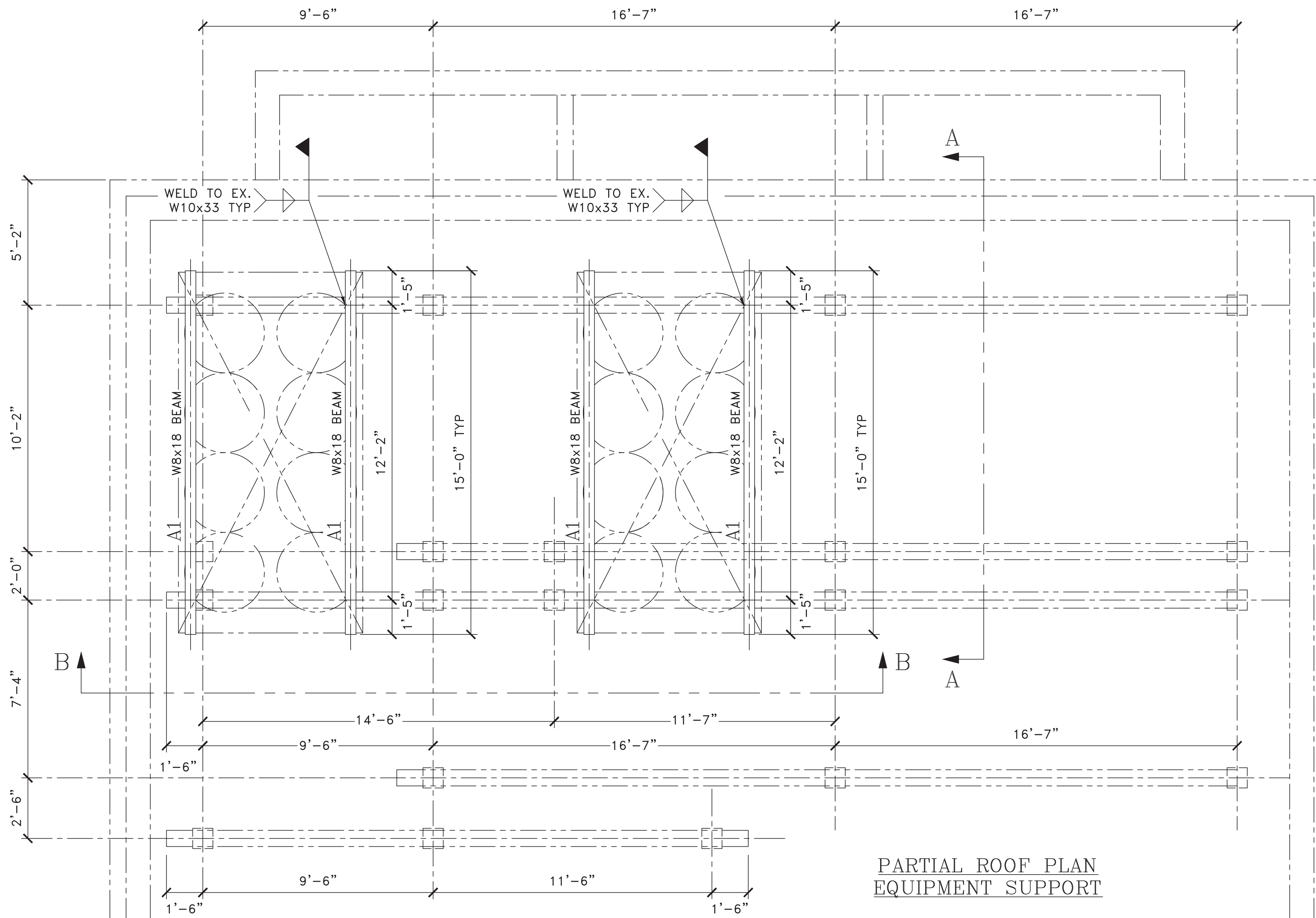

WTA NOTE:
FIELD VERIFY DIMENSIONS

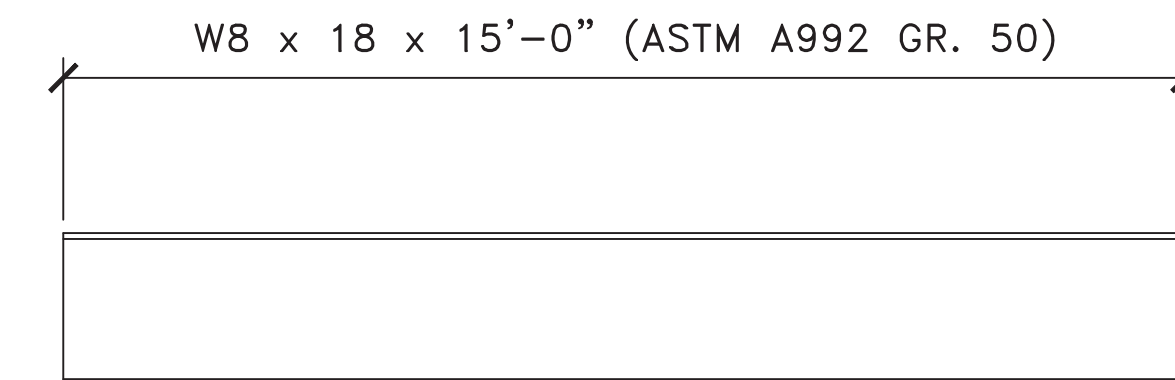

(4) BEAMS A1
(HOT DIPPED GALVANIZED)

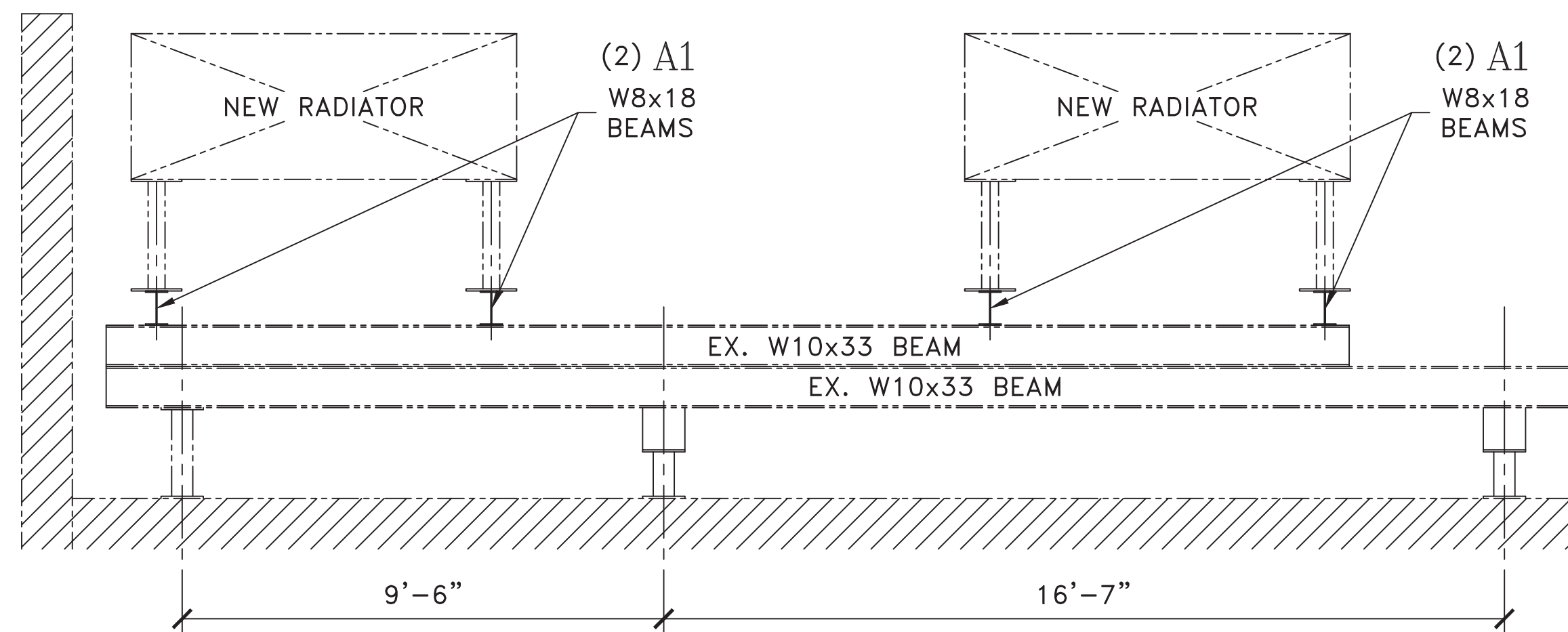

SECTION B-B

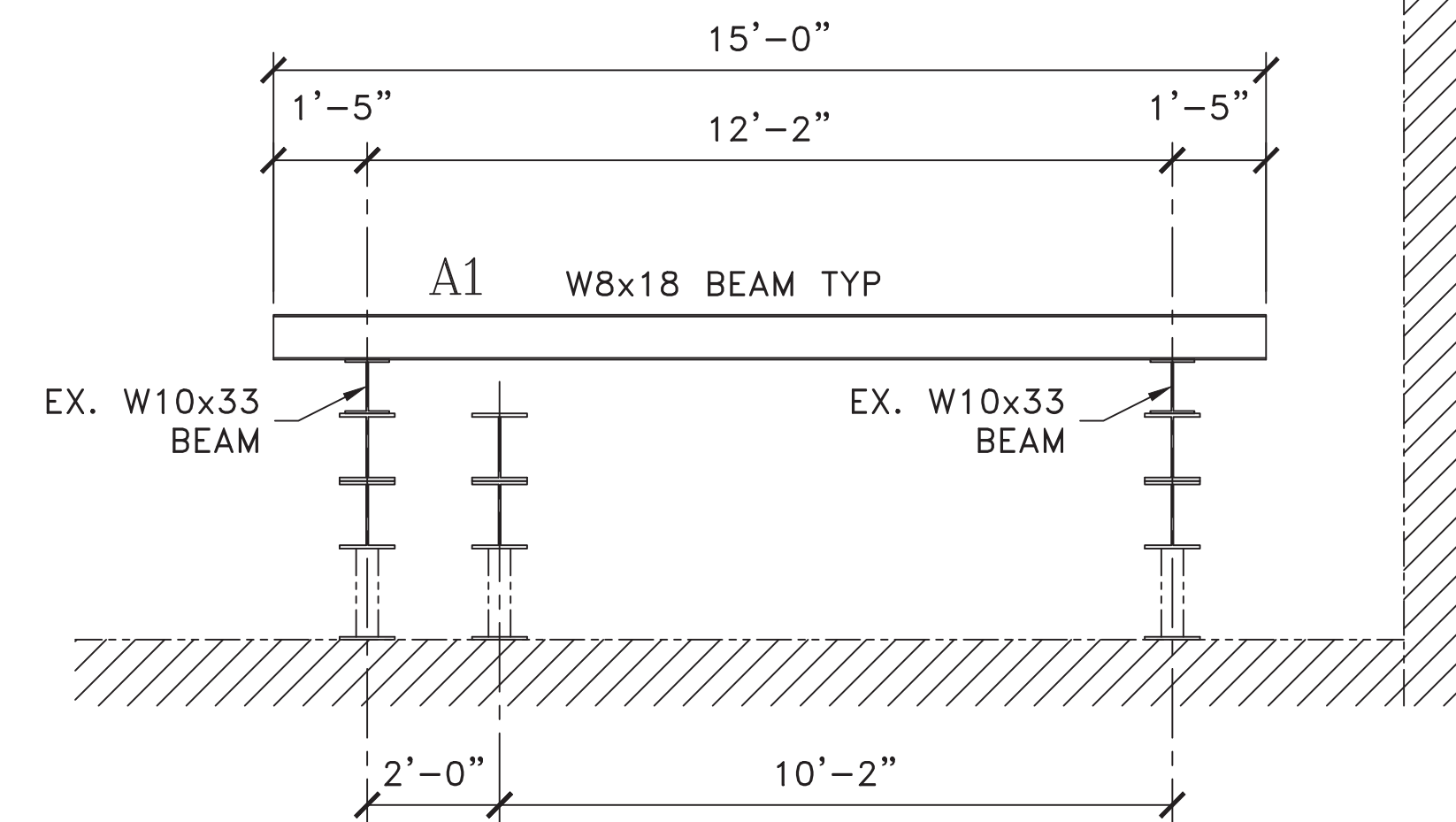

SECTION A-A