

**GENERAL SPECIFICATIONS:**

- THIS IS NOT A LEED CERTIFIED PROJECT
- ALL CABINETS TO BE CONSTRUCTED OF 3/4" PARTICLE BOARD CORE MELAMINE MANUFACTURED BY "ROSEBERG DURAMINE".
- ALL DRAWERS TO BE CONSTRUCTED OF 3/4" MELAMINE W/ 1/4" MDF CORE DRAWER BOTTOMS-MOUNTED TO CABINET ON 100 lb.. FULL-EXTENSION DRAWER SLIDES.
- ALL DOORS TO HAVE BLUM 120° CONCEALED FULL OVERLAY HINGES AND METAL PLATE (FULLY CAM ADJUSTABLE)
- ALL CABINETS TO HAVE 5mm LINE BORING IN 32mm SPACING W/ NICKEL PLATED SHELF PINS.
- ALL PULLS (REFER TO HARDWARE SCHEDULE)
- ALL FINISHES (REFER TO FINISH SCHEDULE)
- ALL OVERALL MEASUREMENTS SUBJECT TO FIELD VERIFICATION (U.N.O.)
- ALL COUNTER TOPS TO BE CONSTRUCTED OF MDF CORE OR INDUSTRIAL GRADE PARTICLE BOARD AT ALL NON-SINK AREAS AND PLYWOOD AT SINK (WET) AREAS COVERED W/ STANDARD GRADE PLASTIC LAMINATE (U.N.O.)
- ALL BACK SPLASHES TO BE 4" TALL UNLESS A 6" IS REQUIRED AT AN ADA COMPLIANT SECTION ON AN ELEVATION (U.N.O.)
- ALL CAM LOCKS TO BE: COMP-X NATIONAL #C8053-C415A-14A ALL KEYED ALIKE (U.N.O.)
- ALL ADJUSTABLE SHELVING TO BE MOUNTED ON EXTRA H.D. KV87 STANDARDS AND KV187 BRACKETS W/ ANOCHROME FINISH. SHELVING TO BE MADE OF WHITE MELAMINE PARTICLE BOARD CORE ROSEBERG "DURAMINE" WITH WHITE EDGE TAPE ON ALL VISIBLE AND SEMI-VISIBLE EDGES (U.N.O.)
- ALL GROMMETS TO BE DRILLED PER CUSTOMER REQUEST AT THE TIME OF INSTALLATION OF MILLWORK. (U.N.O.)
- ALL EQUIPMENT CUT SHEETS ARE REQUIRED PRIOR TO CONSTRUCTION OF MILLWORK.

**FINISH SCHEDULE:**

	MANU.	COLOR NAME	COLOR #
PL-2	PIONITE	RAVEYARD OF THE ATLANTIC	AG611
SS-1	SILESTONE	BLANCO MAPLE	

**CABINET STYLE:**

- P-LAM EXTERIOR.
- PARTICLE BOARD CORE - WHITE INTERIOR.
- MDF CORE - WHITE/BLACK INTERIOR.
- PLYWOOD CORE - WHITE/BLACK INTERIOR.

# ALORICA - HUMBLE

3200 FM 1960  
HUMBLE, TX 77338

**LSM JOB # 2520**

## MACON BUILDING

JIM MACON  
MARK ERICKSON

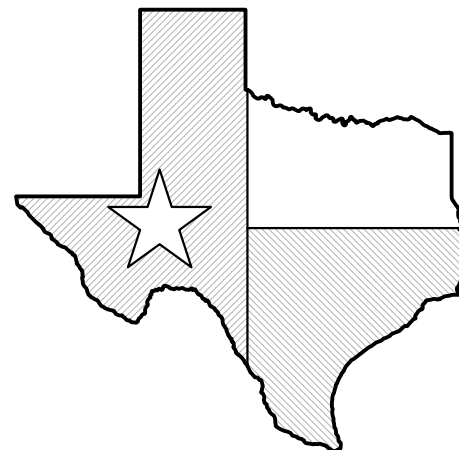

## LONE STAR MILLWORK GROUP, INC.

15180 GRAND POINT RD. HOUSTON, TX 77022  
OFFICE: (713) 691-9100  
FAX: (713) 691-9102

**HARDWARE SCHEDULE:**

- 96mm WIRE PULL - BRUSHED CHROME
- ROUTED-IN FINGER PULLS W/ PVC FINISH
- CAM LOCKS & ELBOW CATCHES PRESENT. REF. ELEVATION FOR KEY PATTERN
- EXTRA H.D. DRAWER SLIDES PRESENT.

**ACKNOWLEDGMENT:**

PLEASE VERIFY ALL PAGES INCLUDING BUT NOT LIMITED TO DIMENSIONS, COLORS, SPECIFIC NOTES AND DETAILS. PLEASE INITIAL ALL PAGES ON THE BOTTOM RIGHT HAND CORNER AND SIGN THIS COVER PAGE WHERE NOTED.

BY SIGNING THIS COVER PAGE, I (SIGNEE) ACKNOWLEDGE THAT I HAVE READ EVERY PAGE THOROUGHLY AND THE DETAILS FOUND ON THESE PAGES ARE CORRECT AND FINAL, UNLESS I (SIGNEE) HAVE NOTED OTHERWISE IN RED INK. I HAVE APPROVED ALL THESE PAGES AND HAVE REVISED IN RED INK THE ITEMS THAT NEED TO BE MODIFIED FOR CONSTRUCTION. I (SIGNEE) FURTHER UNDERSTAND THAT I WILL BE LIABLE FOR EXTRA CHARGES IF ANY CHANGES NEED TO BE MADE AFTER THE DATE OF SIGNATURE IF THE CABINETS HAVE ENTERED INTO PRODUCTION.

- APPROVED AS DRAWN
- REVISE & RE-SUBMIT AS NOTED
- APPROVED AS NOTED
- REJECTED/RE-SUBMIT

SIGNATURE: \_\_\_\_\_ DATE: \_\_\_\_\_

Any reproduction, disclosure or use of any portion of the confidential and proprietary information of Lone Star Millwork Group, Inc., shall be a breach of the obligation of confidence created by the acceptance of this drawing from Lone Star Millwork Group, Inc., Inc. for a specific project or contract. Any copying, duplicating, reproducing, utilization, alteration, modification, revision or change to this drawing, is expressly prohibited unless done with the prior written consent or approval of Lone Star Millwork Group, Inc., and shall not be undertaken without receipt of such prior written approval. This drawing is loaned by Lone Star Millwork Group, Inc., for the limited purpose of complying with a specific contract.

**REVISIONS:**

NO.	DATE	BY.	DESCRIPTION
	N/A	N/A	ORIGINAL SET FOR APPROVAL
1			
2			
3			
4			
5			
6			
7			
8			
9			

**MISC. SCHEDULE:**

- SPECIAL ORDER ITEMS:
- GLASS SUPPLIED BY LSM GROUP, INC.
- PAINT/STAIN GRADE BASE PRESENT.
- TACKABLE FABRIC WRAPPED PANEL PRESENT.



**LONE STAR  
MILLWORK  
GROUP, INC.**

15180 GRAND POINT RD.  
HOUSTON, TX 77090  
OFFICE: 713-691-9100

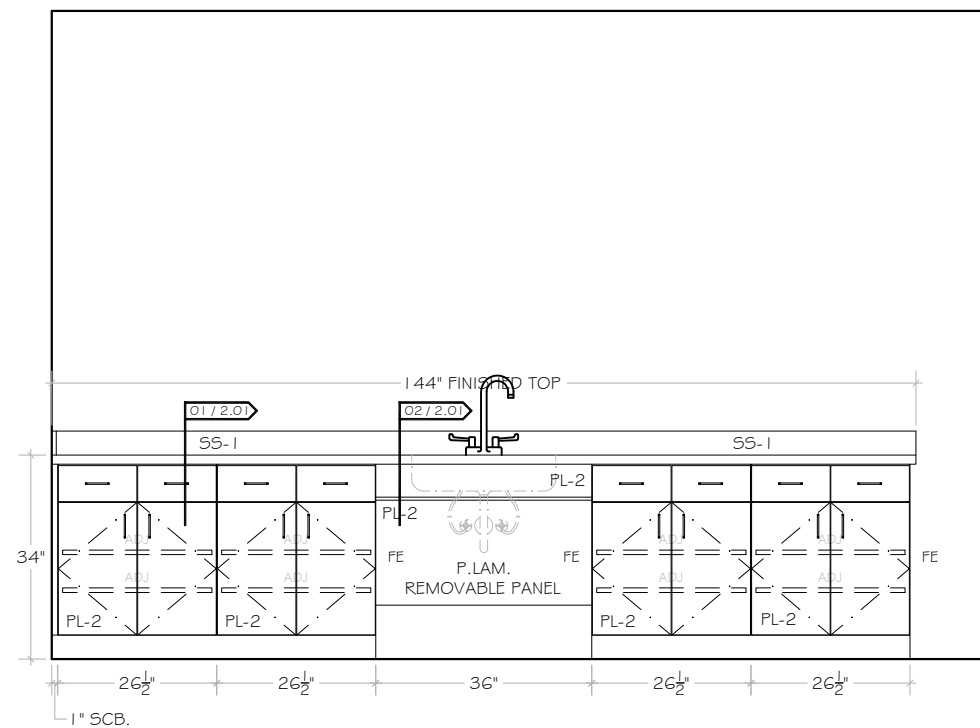

**MILLWORK @ BREAK ROOM 105** A

PL-2 = PIONITE "RAVEYARD OF THE ATLANTIC" #AG611  
SS-1 = SILESTONE "BLANCO MAPLE"

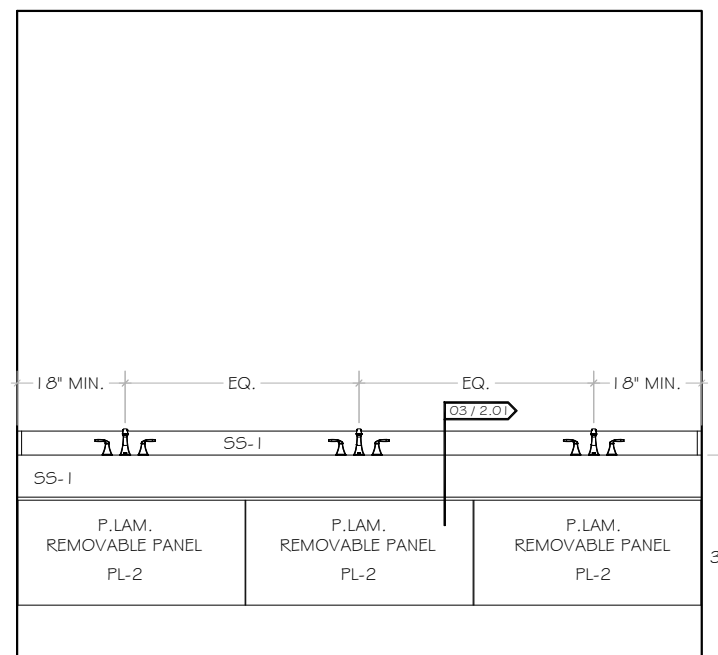
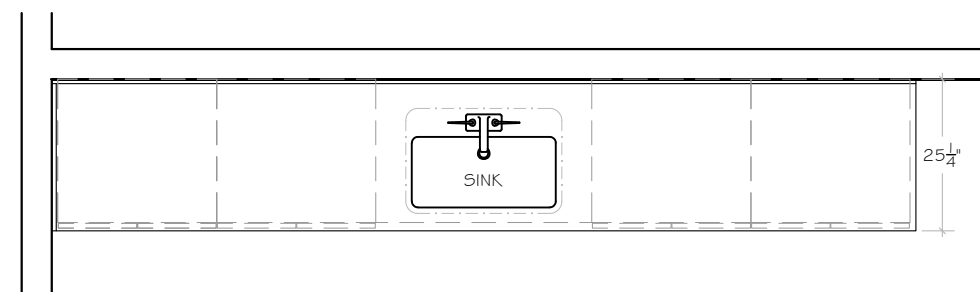

**MILLWORK @ WOMEN'S RR 116** B

PL-2 = PIONITE "RAVEYARD OF THE ATLANTIC" #AG611  
SS-1 = SILESTONE "BLANCO MAPLE"

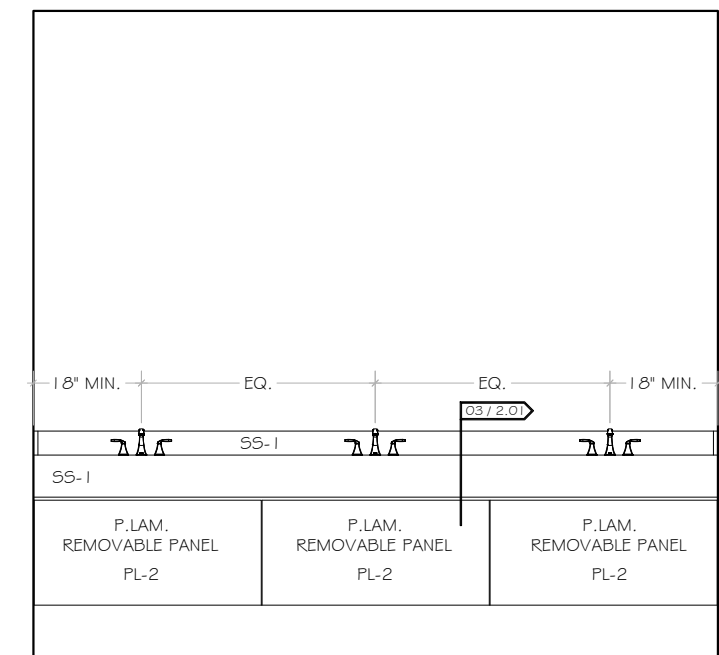
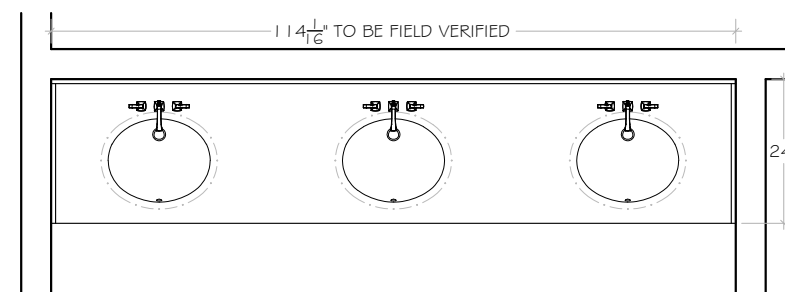

**MILLWORK @ MEN'S RR 118** C

PL-2 = PIONITE "RAVEYARD OF THE ATLANTIC" #AG611  
SS-1 = SILESTONE "BLANCO MAPLE"

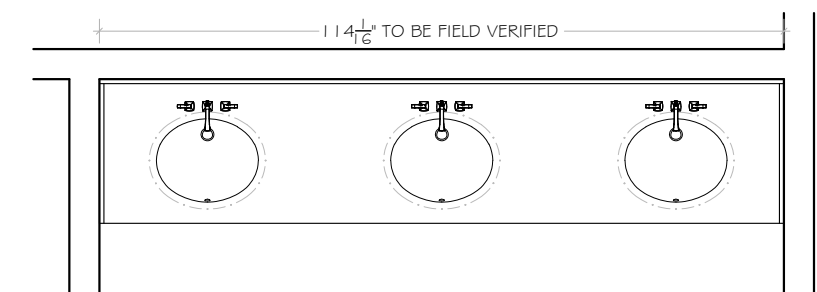

**KEY NOTES:**

**GENERAL NOTES:**

- 1: ALL "HOLD, CLEAR, OR MIN." DIMENSIONS TO BE VERIFIED WITH EQUIPMENT SPEC. SHEETS PRIOR TO CONSTRUCTION OF MILLWORK.
- 2: ALL MILLWORK TO HAVE 96mm BRUSHED CHROME WIRE PULL. UNO
- 3: ALL CABINETS TO HAVE .5 MIL PVC EDGE BANDING TO MATCH P-LAM SELECTION ON ALL EXPOSED AND SEMI-EXPOSED SURFACES WITH WHITE MELAMINE INTERIORS.

HARDWARE #	HARDWARE DESCRIPTION

Project Number: 2520  
Project Title: ALORICA - HUMBLE  
Project Address: 3200 FM 1960  
Project Address: HUMBLE, TX 77338  
Contractor: MACON BUILDING  
Project Manager: JIM MACON

REVISIONS:

No.	Date	By	Description
1	03/30/21	SRT	ORIGINALS

Scale: 3/8" = 1' 0"  
Date Issued: 03/16/21  
Sheet Number: DWG.-1.01



**LONE STAR  
MILLWORK  
GROUP, INC.**

15180 GRAND POINT RD.  
HOUSTON, TX 77090  
OFFICE: 713-691-9100

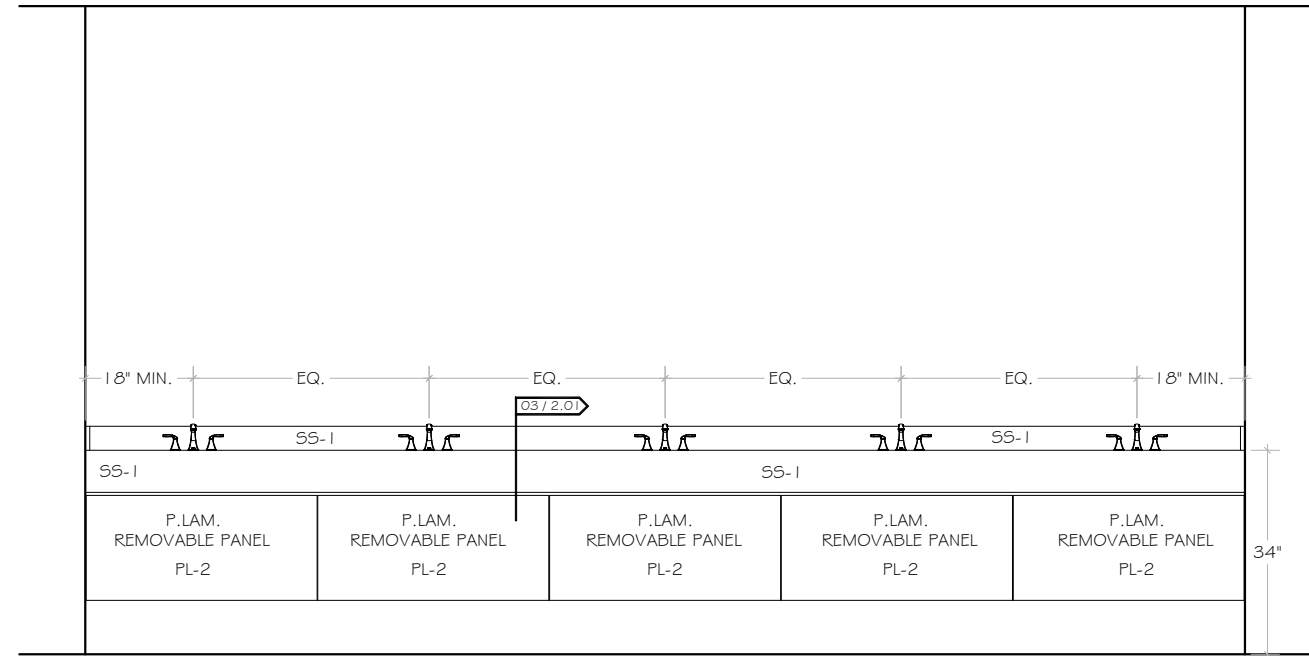
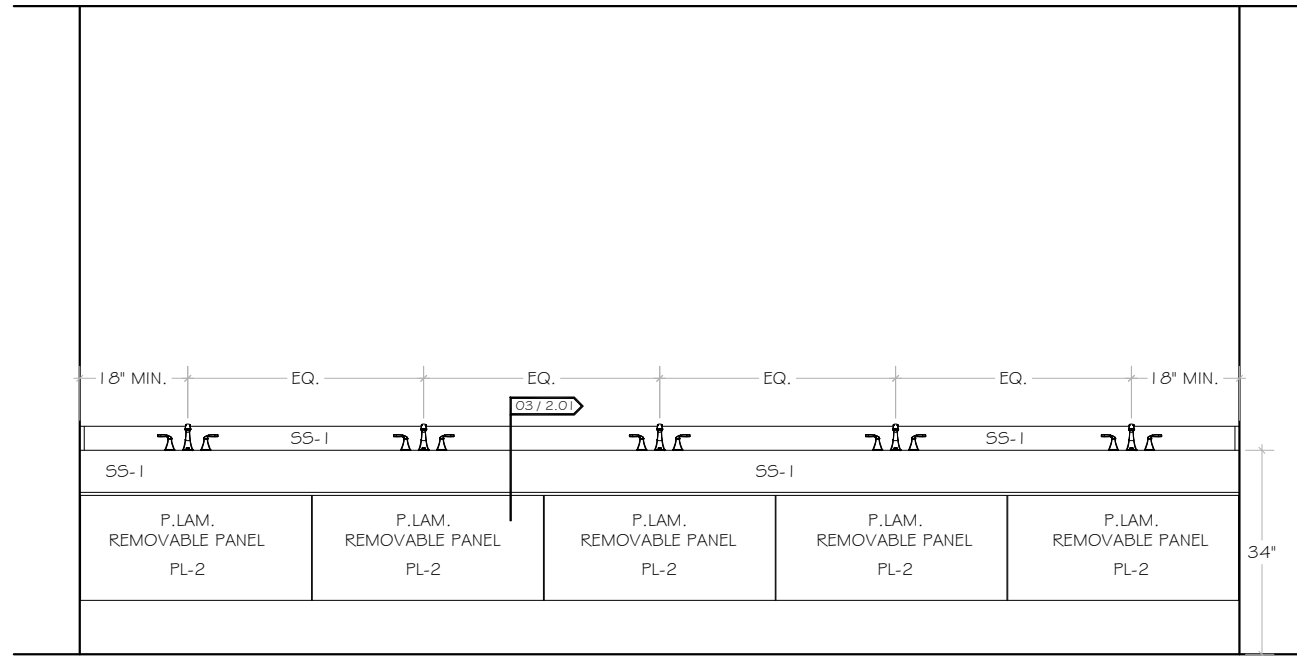

**MILLWORK @ WOMEN'S RR 143** D

3/8" = 1'-0"

PL-2 = PIONITE "RAVEYARD OF THE ATLANTIC" #AGG11  
SS-1 = SILESTONE "BLANCO MAPLE"

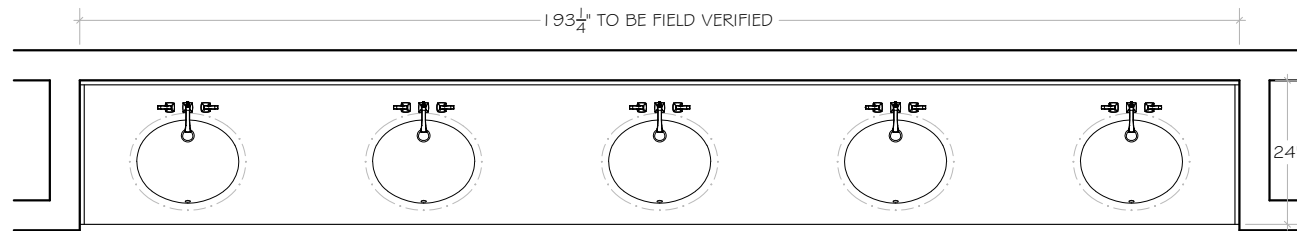

**MILLWORK @ MEN'S RR 144** E

3/8" = 1'-0"

PL-2 = PIONITE "RAVEYARD OF THE ATLANTIC" #AGG11  
SS-1 = SILESTONE "BLANCO MAPLE"

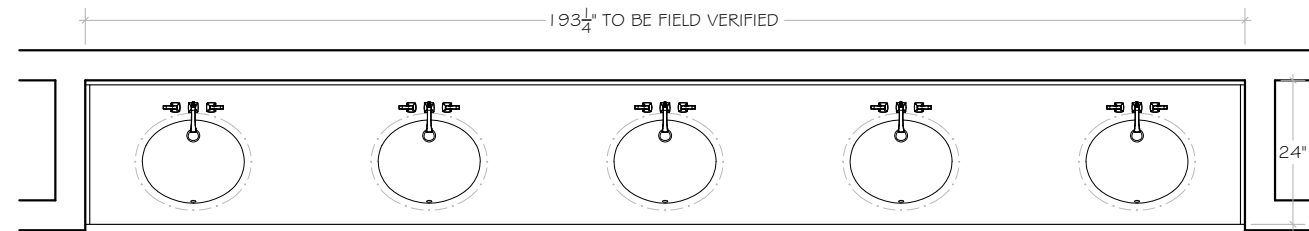

**KEY NOTES:**

**GENERAL NOTES:**

- 1: ALL "HOLD, CLEAR, OR MIN." DIMENSIONS TO BE VERIFIED WITH EQUIPMENT SPEC. SHEETS PRIOR TO CONSTRUCTION OF MILLWORK.
- 2: ALL MILLWORK TO HAVE 96mm BRUSHED CHROME WIRE PULL. UNO
- 3: ALL CABINETS TO HAVE .5 MIL PVC EDGE BANDING TO MATCH P-LAM SELECTION ON ALL EXPOSED AND SEMI-EXPOSED SURFACES WITH WHITE MELAMINE INTERIORS.

HARDWARE #	HARDWARE DESCRIPTION

Project Number: **2520**  
Project Title: **ALORICA - HUMBLE**  
Project Address: **3200 FM 1960**  
Project Address: **HUMBLE, TX 77338**  
Contractor: **MACON BUILDING**  
Project Manager: **JIM MACON**

REVISIONS:			
No.	Date	By	Description
1	03/30/21	SRT	ORIGINALS

Scale	3/8" = 1'-0"
Date Issued	03/16/21
Sheet Number	DWG. - 1.02



**LONE STAR  
MILLWORK  
GROUP, INC.**

15180 GRAND POINT RD.  
HOUSTON, TX 77090  
OFFICE: 713-691-9100

HARDWARE DESCRIPTION

HARDWARE #

Project Number: 2520  
Project Title: ALORICA - HUMBLE  
Project Address: 3200 FM 1960  
Project Address: HUMBLE, TX 77338  
Contractor: MACON BUILDING  
Project Manager: JIM MACON

REVISIONS:			
No.	Date:	By:	Description:
1	03/30/21	SRT	ORIGINALS
2			
3			
4			
5			
6			
7			

Scale 1" = 1'-0"  
Date Issued 03/16/21  
Sheet Number SECT.-2.01

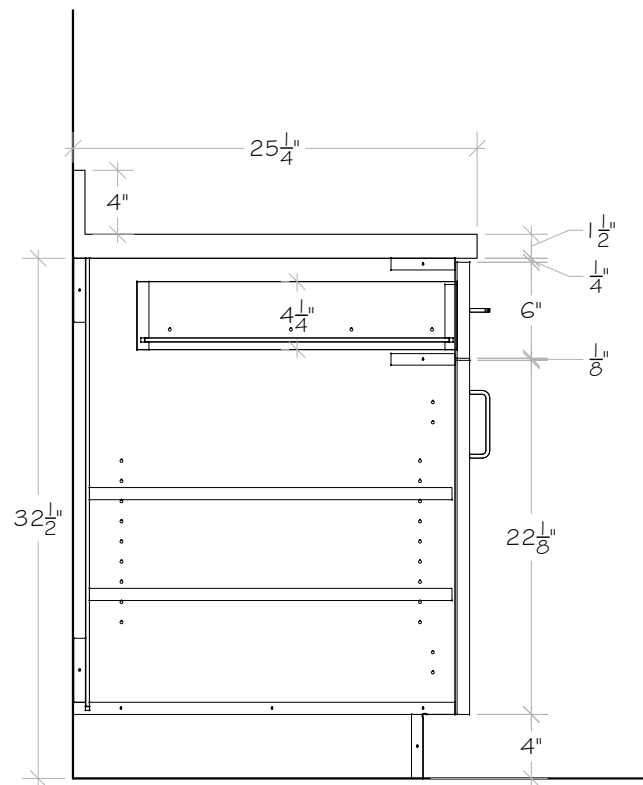

VERT. SECTION 01  
1" = 1'-0"

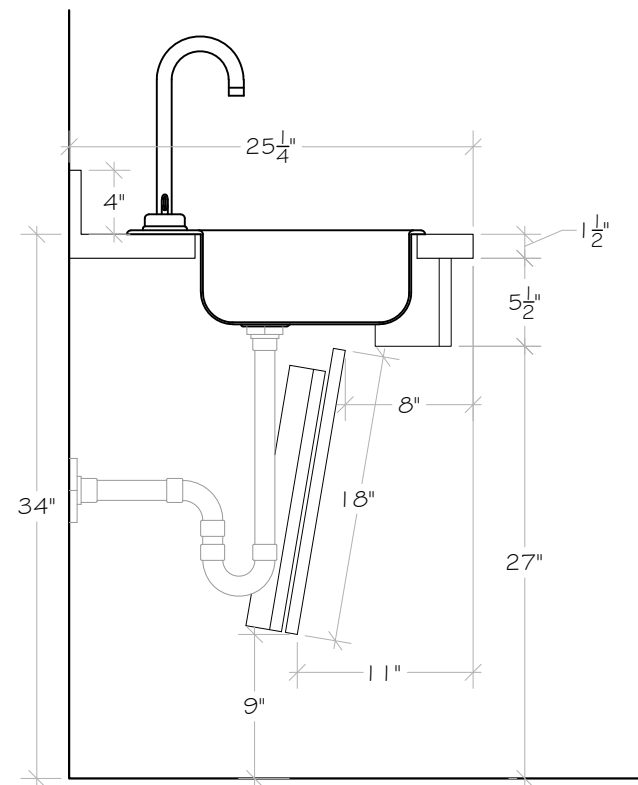

VERT. SECTION 02  
1" = 1'-0"

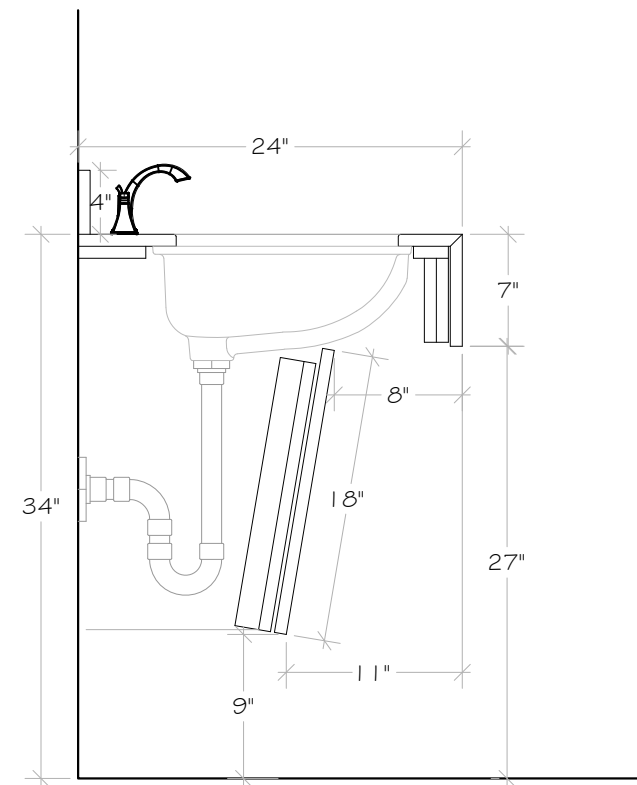

VERT. SECTION 03  
1" = 1'-0"